

The motorized bases TOE moving horizontally reciprocators and, therefore, the guns holder, within the painting installations, either with thermo-hardening dust or paints.

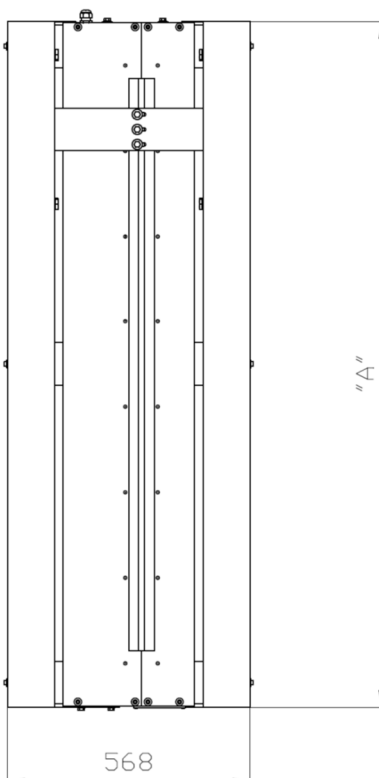
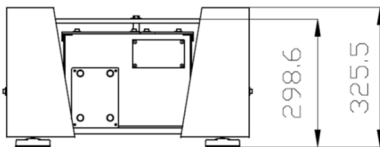
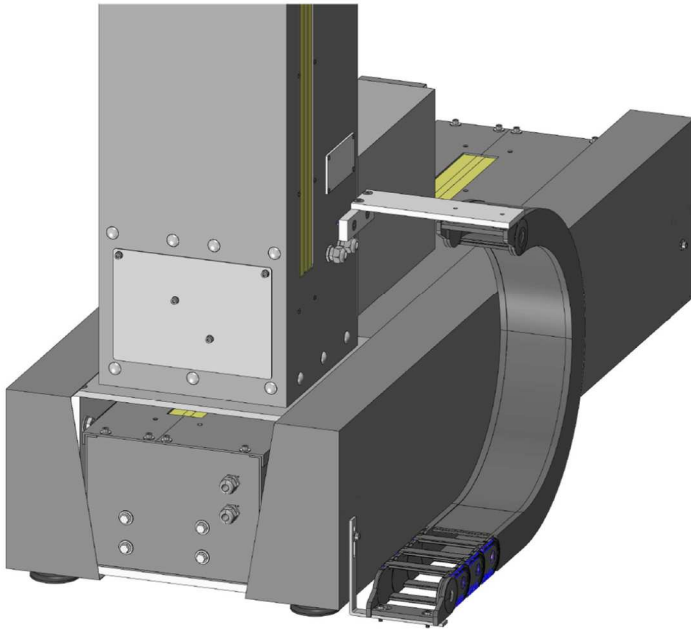

TECHNICAL FEATURES

- Steel framework covered with dust paints.
- Worm gear motor 0.25 [KW].
- Handling guide and translation carriage through toothed belt.
- Dustproof systems.
- Motor control through Inverter.
- Speed regulation.
- Adjustable safety limit switches.
- Light alloy sliding guides with self-cleaning profile.
- Running wheels made of anti-friction materials.
- It is provided with Encoder and horizontal survey system with PLC command.
- Constant stroke at different speeds.
- Digital control of all functions.
- Positioning with 1 [cm] resolution.
- All function and controls can be performed at the control board.

MODEL	TOE 50	TOE 75	TOE 100	TOE 150
TOTAL HEIGHT [mm] "A"	1100	1350	1600	2100
STROKE [mm]	500	750	1000	1500
SPEED MIN [m/min]	1	1	1	1
SPEED MAX [m/min]	10	10	10	10
CONTROL MOTOR	Inverter	Inverter	Inverter	Inverter
MOTOR [kW]	0,25	0,25	0,25	0,25
BELT	Toothed	Toothed	Toothed	Toothed
HANDLING GUIDE CARRIAGE	Wheels	Wheels	Wheels	Wheels
POSITIONING	Selector	Selector	Selector	Selector