

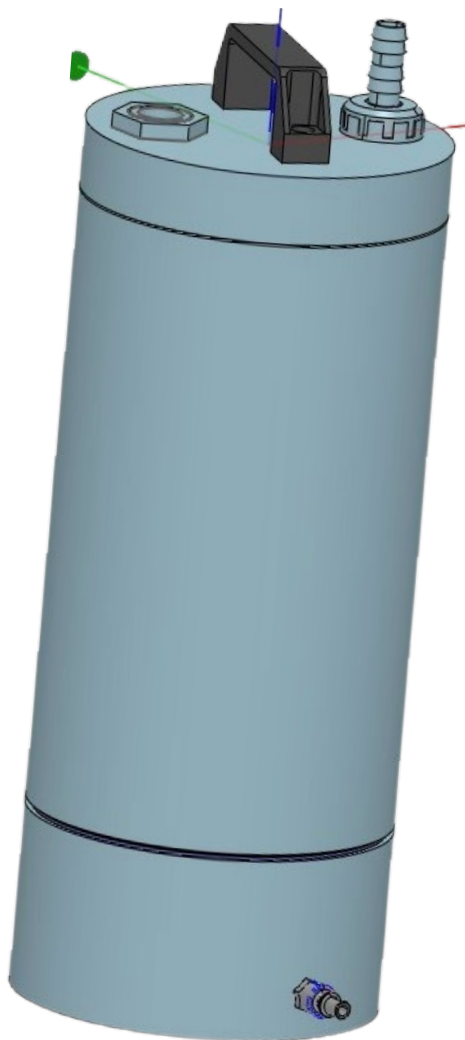

Re Ind SRL
Via Raveto, 12
23851 Galbiate (LC)
ITALY



Azienda con sistema
di gestione ISO 9001
certificato secondo
la norma
UNI EN ISO 9001:2015



REIND CP FAST

The **CP FAST** fluidized powder container is an ideal tool for managing small dust samples efficiently and without production process interruptions. It is specifically designed to improve productivity, minimize downtime due to dust changes or cleaning and ensure safe and controlled handling of the raw material.

Main features

1. Compact and modular design
Ideal for small batches and sampling.
Easy integration into existing lines without the need for structural changes.
2. Advanced fluidization system
Ensures a uniform flow of the dust.
Reduces the risk of clogging or static build-up.

3. Fast and contamination-free powder change
Container easily interchangeable. Ability to manage multiple samples without having to stop the production line.
4. Simplified cleaning
Made entirely of PVC easily washable
Structure designed for rapid removal of dust residues, with times of inactivity reduced to a minimum.
5. Suitable for all kinds of powders
Ability to handle sensitive dust due to precise adjustment of the fluidization.
Benefits for production
6. Minimising interruptions:
Thanks to the modular design and quick changeover to the new colour, production not interrupted during the changes.
7. Greater flexibility:
Suitable for sampling of different types of powders without requiring modifications to the main equipment.
8. Safety and accuracy:
The controlled fluidization, by means of pressure reducer, ensures a management uniform and reduces the risk of dust contamination or dispersion.

Applications

This container is ideal for:

- High quality samples or micro productions
- Additive manufacturing, where dust must be handled with extreme precision.

Conclusion

The **CP FAST** fluidised powder container for small samples is a practical and efficient solution for companies that need to manage dust in a way fast and clean, without compromising the quality or continuity of production. With CP FAST, long interruptions become a problem of the past.

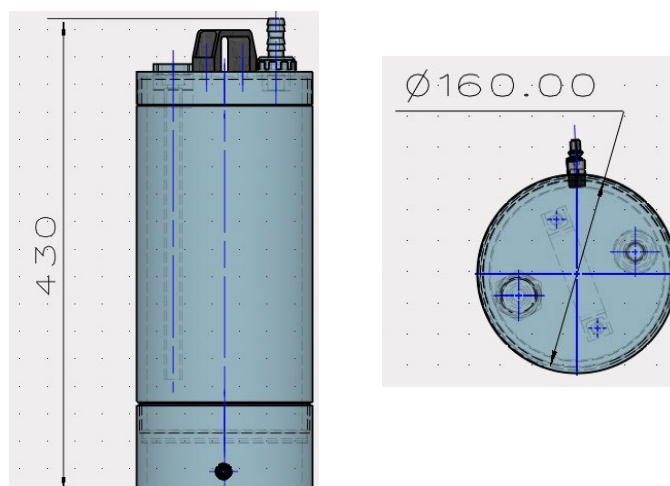

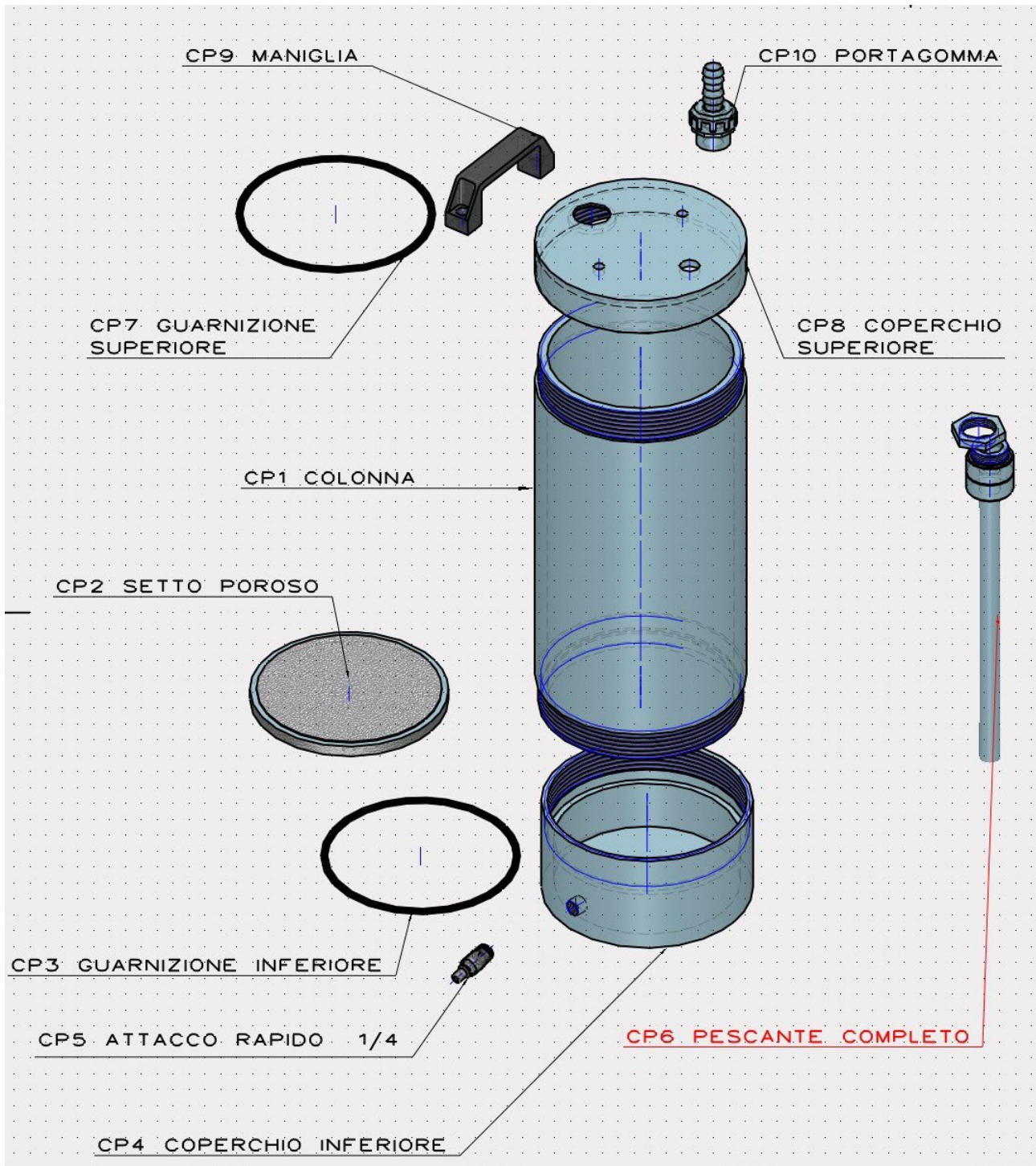

CP1	COLUMN
CP2	POROUS SEPTUM complete with seal
CP3	LOWER GASKET
CP4	LOWER COVER
CP5	QUICK COUPLING 1/4
CP6	FULL SWINGOUT pump housing diameter 20 mm
CP7	TOP SEAL
CP8	TOP COVER
CP9	HANDLE
CP10	HOSE MOUNT D.16



Re Ind SRL
Via Raveto, 12
23851 Galbiate (LC)
ITALY



Azienda con sistema
di gestione ISO 9001
certificato secondo
la norma
UNI EN ISO 9001:2015